



NAMPOWER™

RESOURCE GUIDE

Information on Tool Selection,
Grit Selection, Suggested RPM's and More

GENERAL APPLICATION AND SELECTION OF

NAMPOWER™

DISC BRUSHES



Brush Research Manufacturing is proud to offer the highest quality professional grade tools for deburring, edge radiusing and surface finishing applications on the market today: Nampower™ Disc Brushes. Composed of flexible abrasive nylon filaments bonded to a fiber reinforced thermoplastic base, these abrasive disc brushes contain a unique combination of both ceramic and silicon carbide abrasive that produce maximum burr removal rates and provides an optimum surface finish at the same time. The brushes are available in 2 different styles: Dot Style for general purpose deburring and surface finish applications and the Turbine Style brush for medium and heavy deburring applications.

These high-performance tools create reliable, consistent and cost effective results. Nampower™ Disc Brushes are easily integrated into today's automated machinery, CNC machining centers, transfer lines and robotic cells.

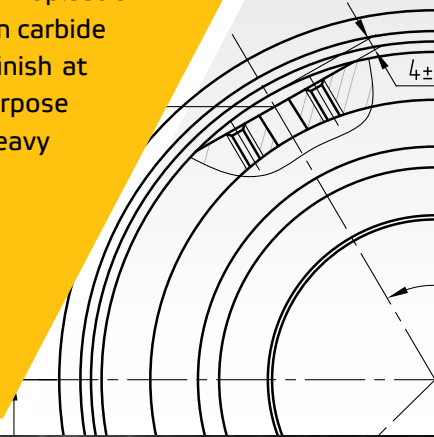

BRUSH SELECTION

DOT STYLE



Used for general purpose edge deburring and surface finishing applications. The Dot style is an economical choice for light deburring applications. Dot style brushes provide greater flexibility and allow entry into small holes and spaces with ease.

TURBINE STYLE



Ideal for medium and heavy deburring applications. The Turbine style brush has a high density fill that is ideal for short cycle times and long tool life.

TRIM LENGTH SELECTION

The Nampower disc brush is available in 18mm and 38mm trim lengths. Trim length selection is about flexibility versus aggressiveness. Longer trim lengths are less aggressive and more flexible while shorter trim lengths are less flexible and more aggressive. Burr size, part shape and conformity, radius requirements and final finish requirements are all factors affecting trim length selection.

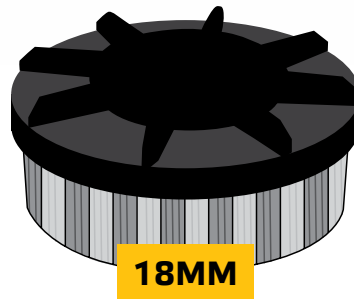
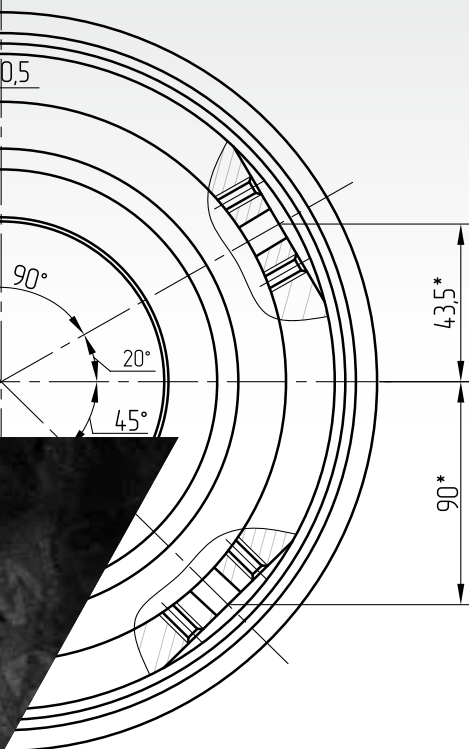

18MM

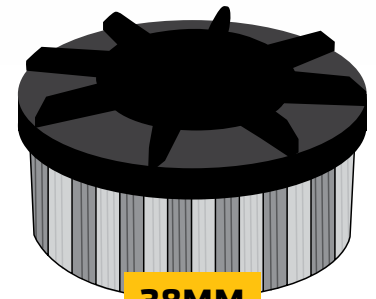

38MM

GRIT SELECTION

GRIT SELECTION

STARTING RA

80	50-60
120	40-50
180	30-40
320	20-30

Grit selection is highly dependent on the starting surface finish and the amount of material refinement required. The general rule of thumb is to choose the coarsest grit possible that will still yield the required surface finish. A fine grit tool used on a coarse starting finish will have less effect on the overall finish improvement as a coarse grit tool followed by a finer grit tool. Coarse grits are recommended for use on heavier burrs or where a fine surface finish is not required.

SELECTING BRUSH DIAMETER, PART COVERAGE

The brush diameter should ideally be larger than the cutting tool used to machine the part. If a smaller brush is required due to fixture restrictions, the centerline of the brush tool should be aligned with the targeted edge with a minimum of 1" of overlap.

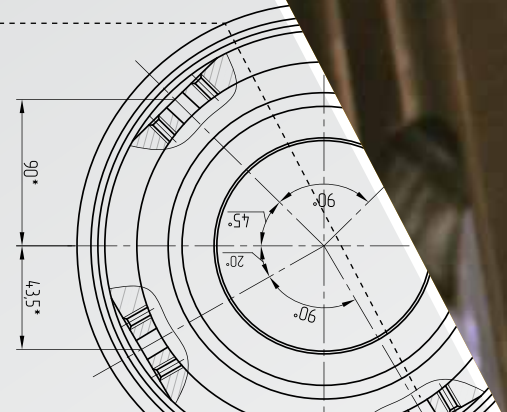
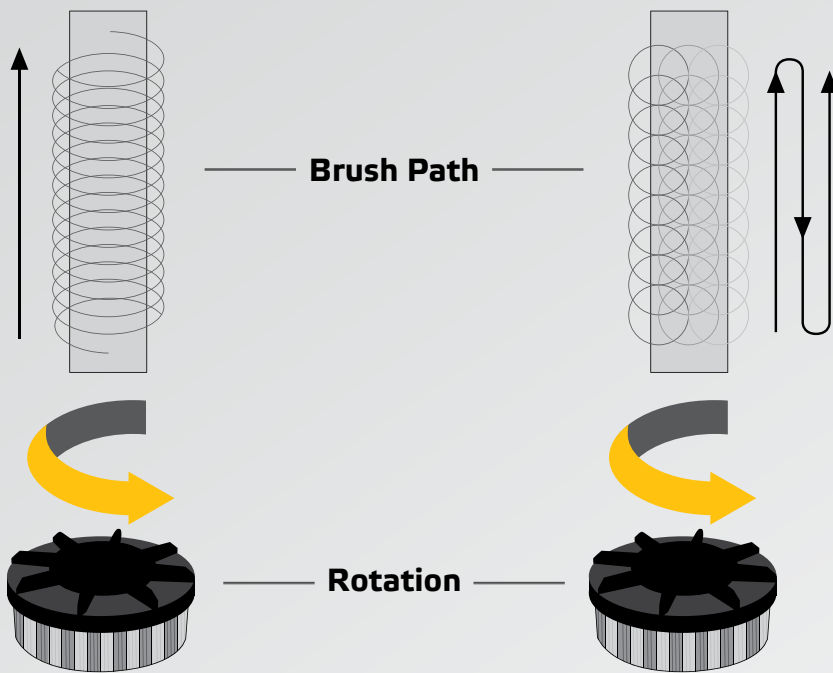

TOOL PATH ROTATIONAL DIRECTION

Tool Path: The brush should be rotating at full speed and start and finish its path completely off the part.

Rotational Direction: The brush should be rotated in the direction opposite of the cutting tool that created the burr on its initial pass.

EASILY INTEGRATED

INTO TODAY'S AUTOMATED MACHINERY,
CNC MACHINING CENTERS, TRANSFER LINES
AND ROBOTIC CELLS

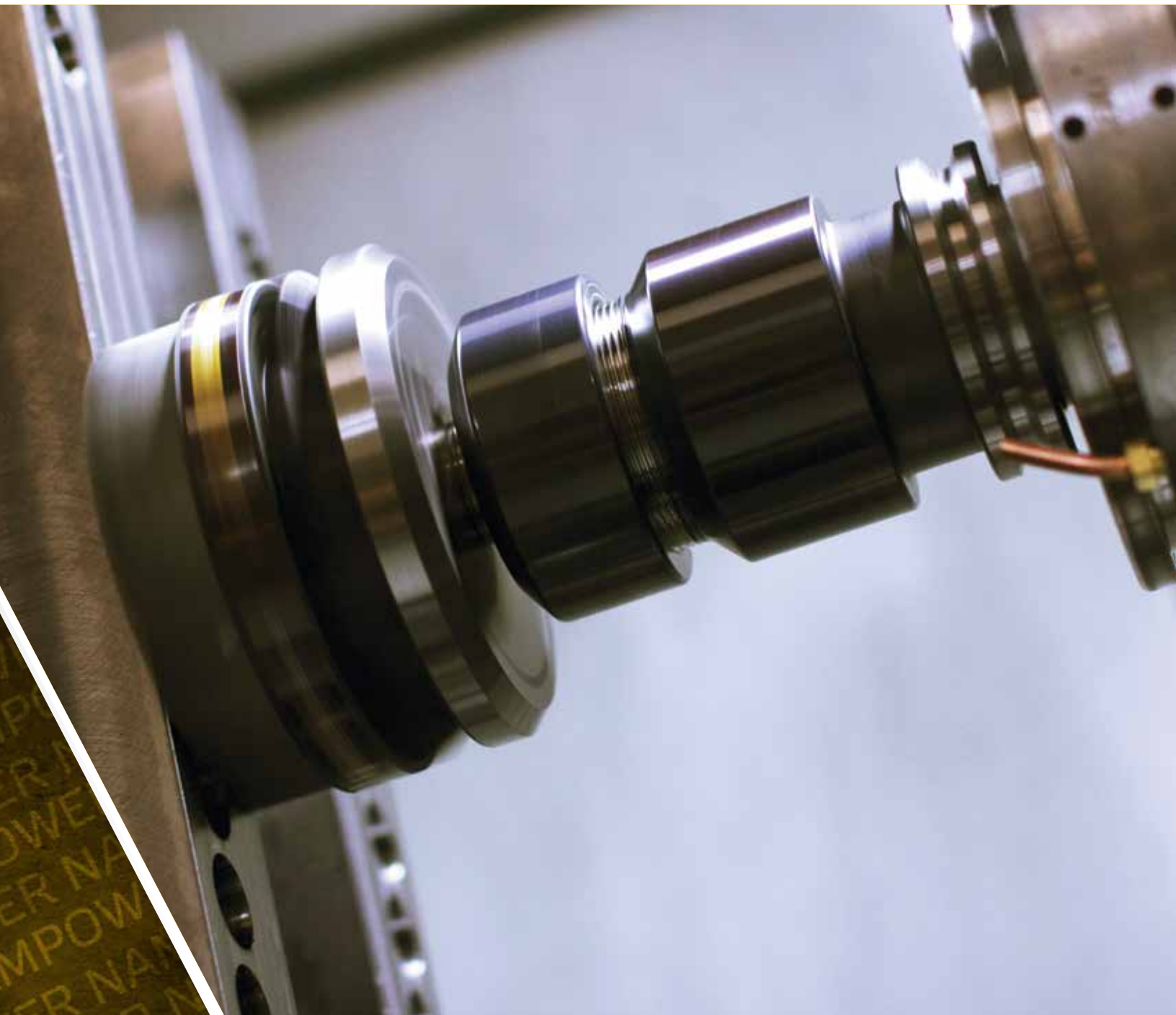

SUGGESTED OPERATING PARAMETERS

DISC SPEEDS

Diameter	80 Grit	120 Grit	180 Grit	320 Grit
50mm	6500	6250	4000	3500
60mm	5500	5000	4000	2750
80mm	4500	4250	3500	2500
100mm	1850	1800	1750	1700
125mm	1600	1550	1500	1450
150mm	1350	1300	1250	1200

The speeds listed in the table above are a guide to be used in establishing the optimum operating RPM. Many factors affect optimum RPM including the brush diameter, trim length, filament diameter, fill pattern, cut depth and if the brush is being run dry or with fluid. The maximum RPM marked on the brush may not be the optimum working speed. It is recommended to stay under 2,500 SFPM in dry applications and 3,500 SFPM in wet applications. A 150mm diameter brush running at 1400 RPM is much more effective than one running at 2800 RPM. Excessive speed, especially with longer trim length, causes the filament to flair and bounces off the work piece. Coarse grit filaments can spin faster than fine grit filaments without flaring. Turbine style fill can spin faster than dot style without flaring. Filaments used with coolant can spin faster than dry applications without overheating and smearing. Typically, higher spindle speeds improve the finish and lower speeds enhance deburring.

BRUSH DEPTH

BRUSH STYLE	CUT DEPTH
Dot Style	.015 – .150
Turbine Style	.004 – .093

Cut depth should be set up to 10% penetration of the available trim length on the finer filament grits (180, 320) and up to 5% penetration on coarser grit filaments (80, 120). Dot Style brushes can be set for a deeper penetration than Turbine Style brushes. Spindle speed is usually decreased with increased depth of interference so the filaments can conform smoothly to part contours.

FEED RATE

MATERIAL	FEED RATE
Non-Ferrous	80 in./min.
Cast Iron	60 in./min.
Mild Steel and Ductile Iron	50 in./min.
Stainless and Alloy Steels	30 in./min.
Titanium and High Nickel Alloys	30 in./min.

Feed rate is affected by many factors including burr size, work piece material, surface contours and finish requirements. Contoured surfaces are processed at slower speeds and greater depth of interference than flat surfaces. Starting feed rates between 30ipm and 80ipm are recommended but the final feed rate is application specific and must be developed through deburring trial.

TYPICAL NAMPOWER™ APPLICATIONS

- Deburring
- Rust removal
- Gasket cleaning & removal
- Roughing
- Finishing prior to painting and plating
- Removal of silicon glue, paper gaskets and flash from rubber and plastic
- Pre-cast concrete mold cleaning
- Spot finishing
- Improve surface finish
- Weld cleaning
- Clean fiberglass
- Plastic automotive parts



APPLICATION GUIDELINES

For More Aggression

- Reduce trim length
- Use larger diameter brush
- Increase grit size
- Use heavy density bristle brush
- Increase spindle RPM
- Increase depth

For Less Aggression

- Increase trim length
- Use smaller diameter brush
- Use finer grit size
- Use medium less density bristle brush
- Reduce pressure

For Contouring

- Increase trim length
- Use fine grit bristle
- Use light density bristle brushes
- Increase pressure

For Fine Finishing

- Use brush with a coolant
- Use long bristle brush
- Increase spindle RPM

For Coarse Finishing

- Use brush without coolant
- Increase grit size
- Use smaller diameter brush
- Reduce spindle RPM

For Smear Free

- Use brush with a coolant work piece
- Use smaller diameter brush
- Reduce spindle RPM
- Decrease pressure

NAMPOWER BRUSHES

DIAMETER	TRIM	GRIT	MSFS	PART # DOT	PART # TURBINE
50mm	18mm	80	6,500	ADD501880	ADT501880
50mm	18mm	120	6,500	ADD5018120	ADT5018120
50mm	18mm	180	6,500	ADD5018180	ADT5018180
50mm	18mm	320	6,500	ADD5018320	ADT5018320
60mm	18mm	80	5,500	ADD601880	ADT601880
60mm	18mm	120	5,500	ADD6018120	ADT6018120
60mm	18mm	180	5,500	ADD6018180	ADT6018180
60mm	18mm	320	5,500	ADD6018320	ADT6018320
80mm	18mm	80	4,000	ADD801880	ADT801880
80mm	18mm	120	4,000	ADD8018120	ADT8018120
80mm	18mm	180	4,000	ADD8018180	ADT8018180
80mm	18mm	320	4,000	ADD8018320	ADT8018320



HOLDER FOR SMALL DISC BRUSHES

PART #	SHANK DIAMETER	HOLDER TYPE
ADH16P	16mm	Standard Collet Flow Through

50mm, 60mm and 80mm brushes are designed to work with our small flow through coolant holder. The 16mm precision ground shank allows coolant to flow from the brush center. This results in better lubricant dispersion which permits the brush to run at greater cut depths and drastically reduces heat generation. These holders are made using a one-piece construction that results in greatly improved balance. All tool holders are heat treated and have a PVD coating for improved corrosion resistance and long life.



NAMPOWER BRUSHES

DIAMETER	TRIM	GRIT	MSFS	PART # DOT	PART # TURBINE
100mm	18mm	80	2,200	ADD1001880	ADT1001880
100mm	18mm	120	2,200	ADD10018120	ADT10018120
100mm	18mm	180	2,200	ADD10018180	ADT10018180
100mm	18mm	320	2,200	ADD10018320	ADT10018320
100mm	38mm	80	2,200	ADD1003880	ADT1003880
100mm	38mm	120	2,200	ADD10038120	ADT10038120
100mm	38mm	180	2,200	ADD10038180	ADT10038180
100mm	38mm	320	2,200	ADD10038320	ADT10038320
125mm	18mm	80	2,000	ADD1251880	ADT1251880
125mm	18mm	120	2,000	ADD12518120	ADT12518120
125mm	18mm	180	2,000	ADD12518180	ADT12518180
125mm	18mm	320	2,000	ADD12518320	ADT12518320
125mm	38mm	80	2,000	ADD1253880	ADT1253880
125mm	38mm	120	2,000	ADD12538120	ADT12538120
125mm	38mm	180	2,000	ADD12538180	ADT12538180
125mm	38mm	320	2,000	ADD12538320	ADT12538320
150mm	18mm	80	1,800	ADD1501880	ADT1501880
150mm	18mm	120	1,800	ADD15018120	ADT15018120
150mm	18mm	180	1,800	ADD15018180	ADT15018180
150mm	18mm	320	1,800	ADD15018320	ADT15018320
150mm	38mm	80	1,800	ADD1503880	ADT1503880
150mm	38mm	120	1,800	ADD15038120	ADT15038120
150mm	38mm	180	1,800	ADD15038180	ADT15038180
150mm	38mm	320	1,800	ADD15038320	ADT15038320

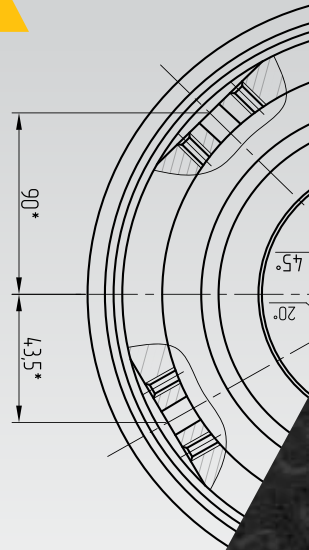

HOLDERS FOR LARGE DISC BRUSHES

PART #	SHANK DIAMETER	HOLDER TYPE
ADHLWMP	25mm	Standard Collet Flow Through
ADHLWMSL	25mm	Standard Sidelock Collet Flow Through



100mm, 125mm and 150mm brushes are designed to work with our large flow though coolant holder. The 25mm shank is available in standard or side-lock configuration and allows coolant to flow from the brush center resulting in better lubricant dispersion which permits the brush to run at greater cut depths and drastically reduces heat generation. The large holder is made using a carbon fiber reinforced thermoplastic material bonded to a hardened and ground steel shank which results in a more rigid, well balanced and lighter weight holder.

GENERAL APPLICATION AND SELECTION OF

NAMPOWER™

COMPOSITE HUB WHEEL BRUSHES



Brush Research's NamPower™ composite hub wheel brushes are abrasive nylon brushing tools for machine-based and offhand deburring, surface finishing, and edge radiusing. These safe, dependable radial wheel brushes feature molded cores that allows higher filament density which results in better brush performance. Their unique, balanced construction puts more cutting tips at the point of attack. As a safer alternative to wire wheels and with a performance advantage over non-woven abrasive brushes, NamPower composite hub wheel brushes are used in the production of turbine blades, steel gears, machine parts, extrusion cut-offs and shaft finishing. Diamond filament wheel brushes are used to produce an edge radius on cutting tool inserts and to polish the flute relief on drills and end mills. When selecting composite hub wheel brushes, as with all industrial brushes, it is important to consider the proper diameter, face width, and trim length. The brush's face width must be wide enough to deburr a wide edge but also narrow enough to access part recesses that may also need finishing. The abrasive grit selected will affect cutting and finish. Grit selection influences flexibility as well. The coarser the abrasive grit (lower number), the larger the filament diameter is which results in a less flexible, more aggressive brush.

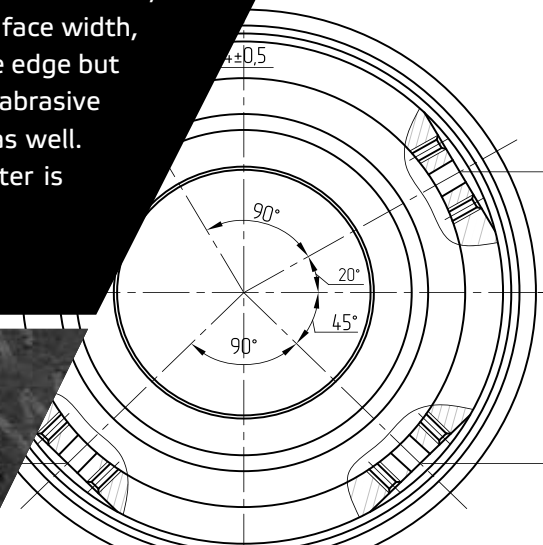

BRUSH DIAMETER SELECTION

Standard Nampower Composite Hub Wheels come in 6 inch and 8 inch diameters. Diamond wheel brushes are available in 4 inch (100mm), 6 inch (150mm) and 8 inch (200mm) diameters. Larger diameter brushes are less aggressive and more flexible while shorter smaller diameter brushes are less flexible and more aggressive. Burr size, part shape and conformity, radius requirements, final finish requirements and the machinery the brush is used on are all factors affecting brush diameter selection.

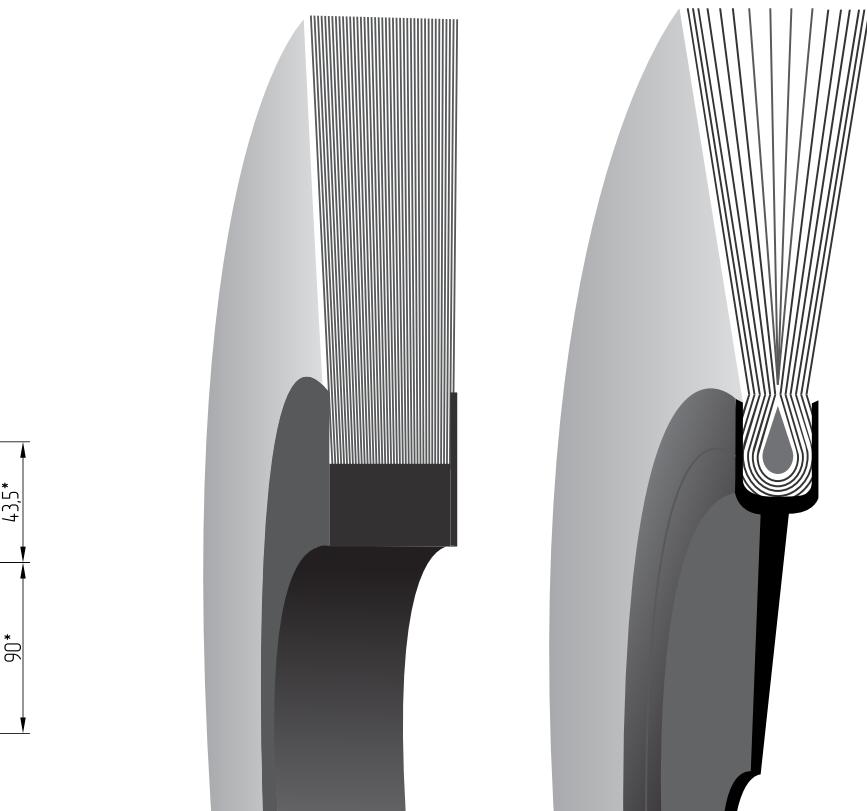
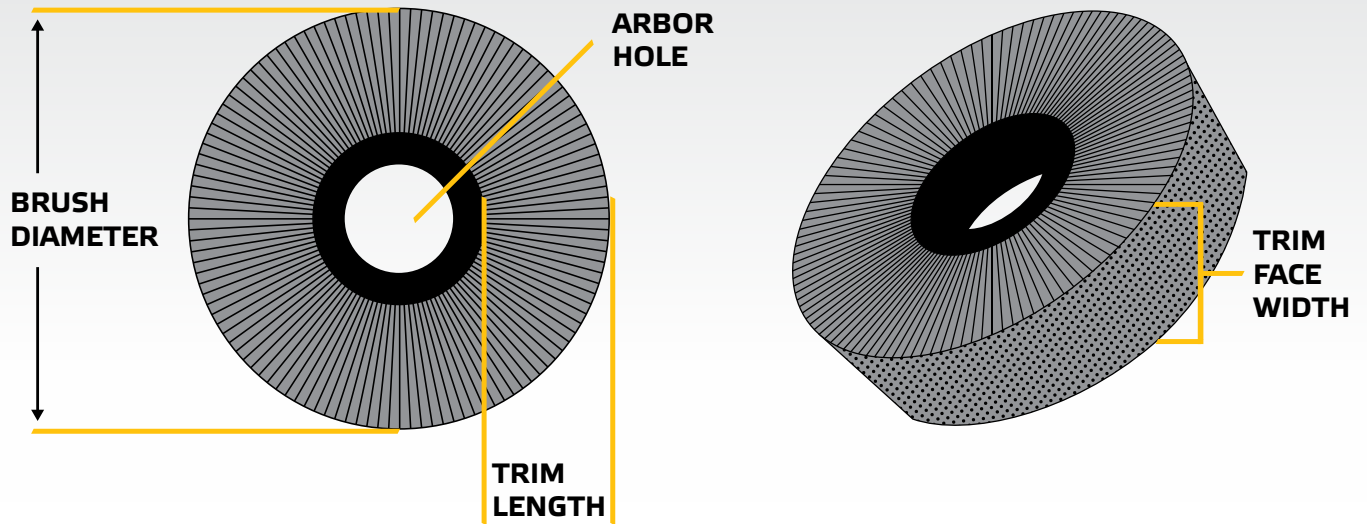

BRUSH CONSTRUCTION

Composite hub brush construction features abrasive filled filaments set into molded cores that allows higher filament density. This unique, balanced construction puts more cutting tips at the point of attack which results in better brush performance, less filament breakage and more even brush wear. Composite hub wheel brushes are a safer alternative to wire wheels and with a performance advantage over non-woven abrasive brushes.

NAMPOWER WHEEL BRUSHES

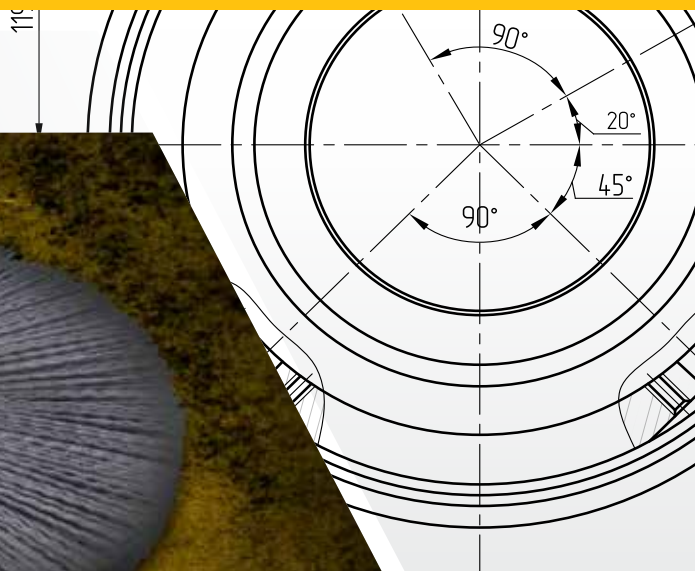

ABRASIVE NYLON WHEELS

DIAMETER	FACE WIDTH	TRIM LENGTH	ARBOR HOLE	GRIT	PART NUMBER
6" (152mm)	1/2"	1 - 1/2"	2"	.040/80 SC	CW61280SC
6" (152mm)	1/2"	1 - 1/2"	2"	.022/120 SC	CW612022120SC
6" (152mm)	1/2"	1 - 1/2"	2"	.040/120 SC	CW612040120SC
6" (152mm)	1/2"	1 - 1/2"	2"	.035/180 SC	CW612180SC
6" (152mm)	1/2"	1 - 1/2"	2"	.022/320 SC	CW612320SC
6" (152mm)	1/2"	1 - 1/2"	2"	.018/500 SC	CW612500SC
6" (152mm)	1"	1 - 1/2"	2"	.040/80 SC	CW6180SC
6" (152mm)	1"	1 - 1/2"	2"	.022/120 SC	CW61022120SC
6" (152mm)	1"	1 - 1/2"	2"	.040/120 SC	CW61040120SC
6" (152mm)	1"	1 - 1/2"	2"	.035/180 SC	CW61180SC
6" (152mm)	1"	1 - 1/2"	2"	.022/320 SC	CW61320SC
6" (152mm)	1"	1 - 1/2"	2"	.018/500 SC	CW61500SC
8" (203mm)	1/2"	2 - 1/2"	2"	.040/80 SC	CW81280SC
8" (203mm)	1/2"	2 - 1/2"	2"	.022/120 SC	CW812022120SC
8" (203mm)	1/2"	2 - 1/2"	2"	.040/120 SC	CW812040120SC
8" (203mm)	1/2"	2 - 1/2"	2"	.035/180 SC	CW812180SC
8" (203mm)	1/2"	2 - 1/2"	2"	.022/320 SC	CW812320SC
8" (203mm)	1/2"	2 - 1/2"	2"	.018/500 SC	CW812500SC
8" (203mm)	1"	2 - 1/2"	2"	.040/80 SC	CW8180SC
8" (203mm)	1"	2 - 1/2"	2"	.022/120 SC	CW81022120SC
8" (203mm)	1"	2 - 1/2"	2"	.040/120 SC	CW81040120SC
8" (203mm)	1"	2 - 1/2"	2"	.035/180 SC	CW81180SC
8" (203mm)	1"	2 - 1/2"	2"	.022/320 SC	CW81320SC
8" (203mm)	1"	2 - 1/2"	2"	.018/500 SC	CW81500SC

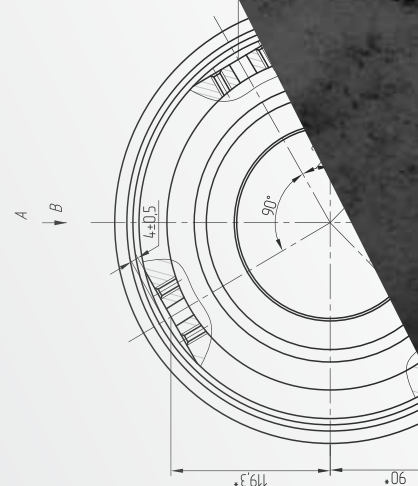

NAMPOWER WHEEL BRUSHES

DIAMOND WHEELS

DIAMETER	FACE WIDTH	TRIM LENGTH	ARBOR HOLE	GRIT	PART NUMBER
100mm (3.94")	5mm	12.5mm	20mm	.012/600	DW100X5X600
150mm (5.91")	10mm	19mm	3-1/4"	.012/600	DW150X10X600
150mm (5.91")	15mm	19mm	3-1/4"	.012/600	DW150X15X600
200mm (7.87")	10mm	30mm	3-1/4"	.012/600	DW200X10X600
200mm (7.87")	15mm	30mm	3-1/4"	.012/600	DW200X15X600



For machine based or off-hand deburring processes, Nampower™ Composite Hub radial wheels offer a safe, durable alternative to wire wheels or non-woven abrasives. Their construction and flexibility provide a long lasting wheel with less filament breakage and superior performance.

- + Higher filament density for longer brush life
- + Shorter parts cycle time and increased aggression
- + Less filament breakage
- + A virtually indestructible core
- + Wider hub thickness with uniformly distributed filaments
- + Balanced construction that reduces machine fatigue

ARBOR ADAPTERS

ARBOR SIZE	COMPOSITE WHEEL ADAPTER	DIAMOND WHEEL ADAPTER
1/2"	CWA2-12	DWA314-12
5/8"	CWA2-58	DWA314-58
3/4"	CWA2-34	DWA314-34
20mm	CWA2-20MM	DWA314-20MM
7/8"	CWA2-78	DWA314-78
1"	CWA2-1	DWA314-1
1-1/4"	CWA2-114	DWA314-114
1-1/2"	CWA2-112	DWA314-112



Brush Research produces arbor adapters in a variety of sizes. The adapters are reusable and machined from solid aluminum and designed to offer increased brush support, less brush vibration and longer brush life. DWA adapters are designed for diamond wheels and CWA adapters are designed for standard composite hub wheels.

SUGGESTED OPERATING PARAMETERS

WHEEL DIAMETER

RPM

	DRY	WET	NOMINAL
4" / 100mm	3400	2400	2800
6" / 150mm	1500	2250	1750
8" / 200mm	1250	1650	1500

* It is suggested to stay under 2,500 SFPM in dry applications and 3,500 SFPM in wet applications

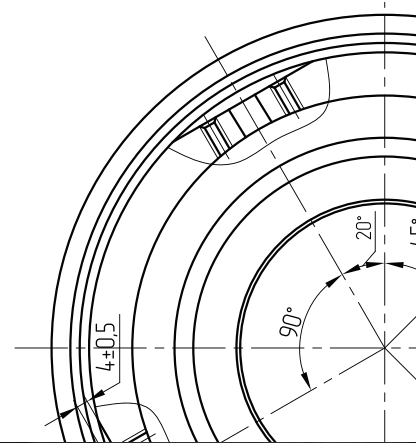

NAMPOWER

WHEEL BRUSHES ARE IDEAL FOR REMOVING SHARP EDGES FROM METAL PARTS AND CREATING A DESIRED EDGE RADIUS.



CUT DEPTH

DIAMETER/GRIT	4" WHEEL	6" WHEEL	8" WHEEL
.012/600	0.050	0.070	0.110
.018/500		0.150	0.250
.022/320		0.150	0.250
.022/120		0.150	0.250
.035/180		0.075	0.125
.040/80		0.075	0.125
.040/120		0.075	0.125

*Standard setup is 10% penetration of the available trim length on the smaller diameter filaments and 5% penetration on larger diameter filaments.

FEED RATE

Once brush diameter, grit selection, RPM and depth of cut are established the feed rate can be determined empirically. Set the feed rate at the fastest rate that will produce the desired level of deburring/edge radiusing.

Optimal brush life and finishing properties are obtained by finding the proper balance between brush speed (RPM), part penetration, and line speed. Lower speeds and lighter pressure give longer brush life, generate less heat, and require less power. Where higher brush speeds and pressures are required, it is recommended to use a more aggressive brush tool. Heat adversely affects the life and performance of the nylon filaments. Applying coolant whenever available is recommended.

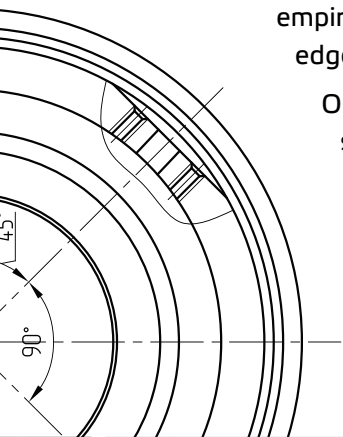



4642 FLORAL DRIVE
LOS ANGELES, CA 90022
TELEPHONE: +1 323-261-2193
FAX: +1 323-268-6587

